

G.C.C

DENOMINATION

Espumoso 75 cl

Model Nr.

020

Mold. N° 03004

TEHNICAL DATA

Capacity 750 ml
Capacity Brimf: 775±10ml
Weight (grs.): 630
Finish : Cava-29
Colour : Green, FM.

Thikness of the glass bottle walls:
not less than 1.5mm.

Thikness of the glass bottle bottom:
not less than 3mm.

USE LIMITS

Carbonated level:

Termoshock.max (°C): <40°C

Pressure max (bar): 14

Axial loading max.(kg.)

Vertical durability max.(kg)

TOLERANCES (mm)

Verticality: ± 3.3

Height: ± 1.8

Diameter: ± 1.6

SURFACE TREATMENT

Hot end coating : yes

Cold end coating : yes

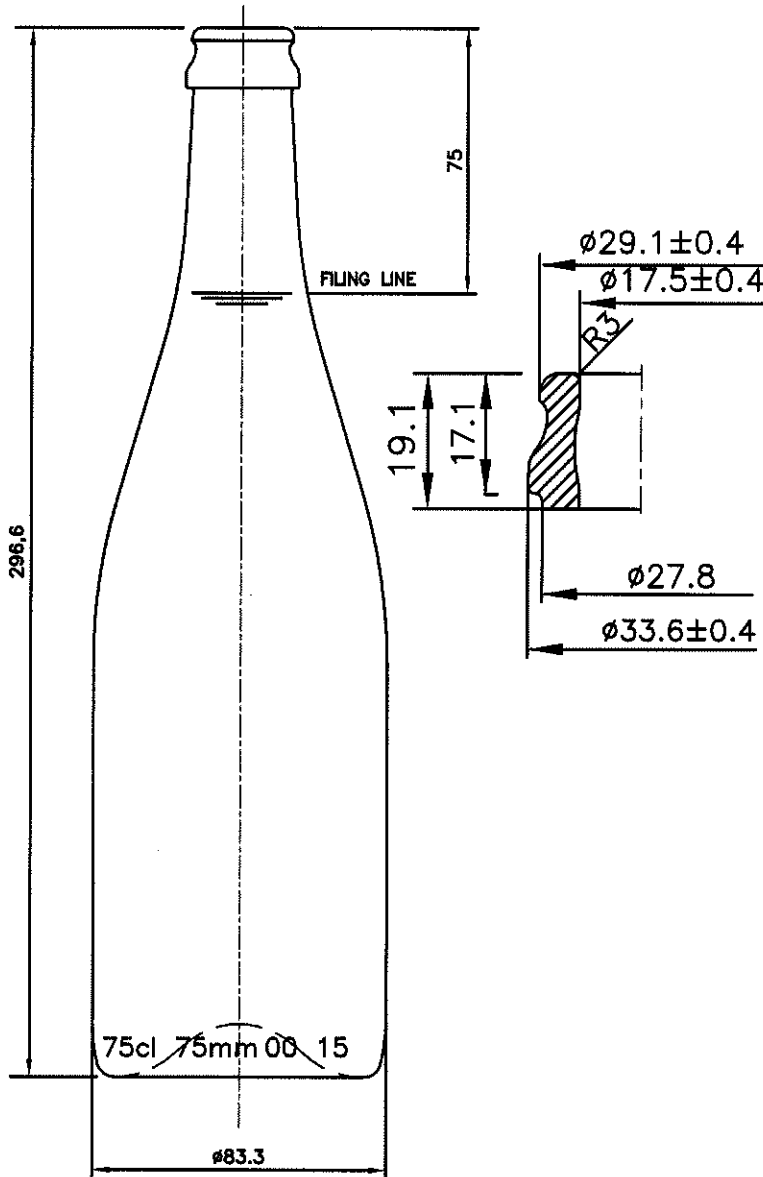

LAYOUT OF BOTTLES IN A PALLET

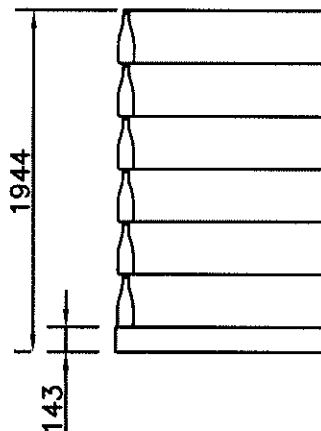
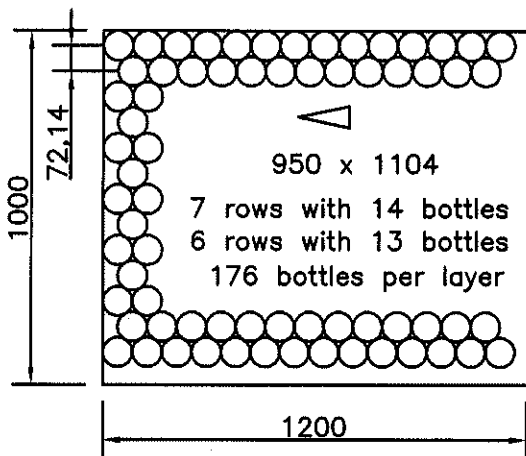

Nr of layers in a pallet: 6
Nr of bottles in a pallet : 1056
Pallet weight (Kg): 710

Pallet : 1200x1000
Lower tray : 1050x1200
Middle tray : 1050x1200
Cover: Cardboard
Wrappage : shrinkwrap film